

M4 TITANIUM HAMMER HEAD BOLT/NUT INSTALLATION

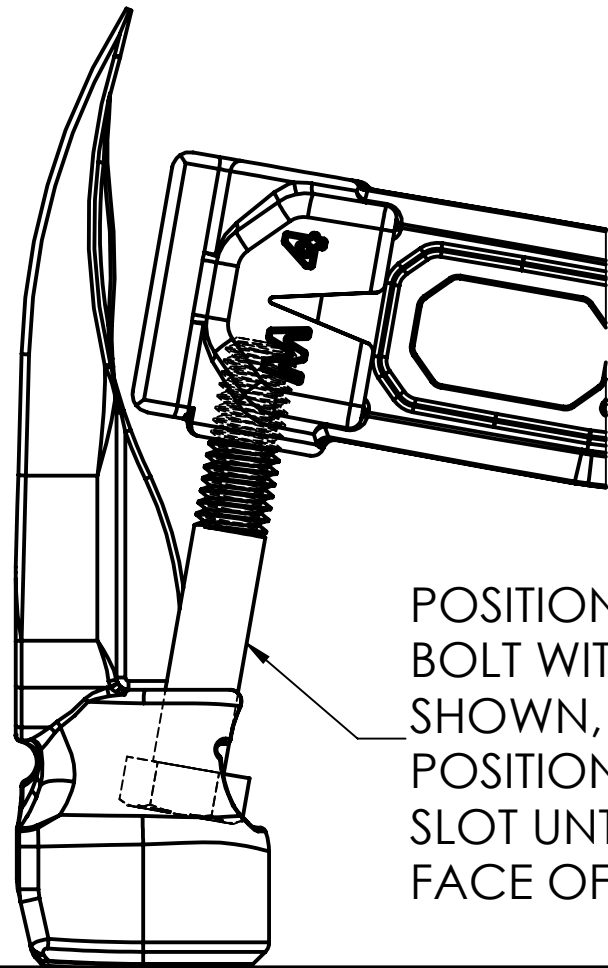

POSITION 3/8-16 X 2 1/4 LONG BOLT WITH HEX HEAD IN SLOT AS SHOWN, ROCK HANDLE INTO POSITION TO POUND DOWN SLOT UNTIL IT CONTACTS THE FACE OF THE HAMMER HEAD.

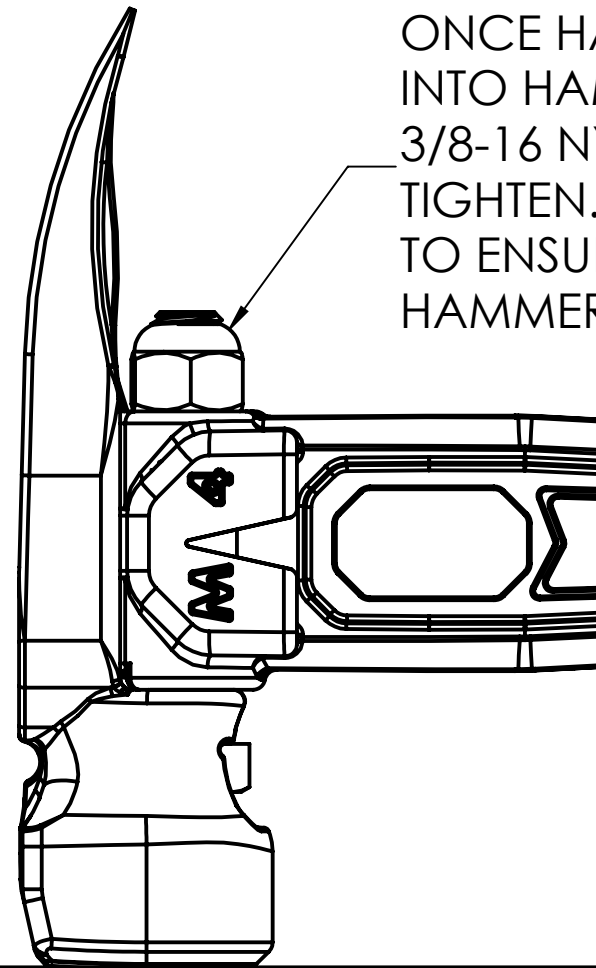

ONCE HANDLE IS FULLY INSERTED INTO HAMMER HEAD INSTALL 3/8-16 NYLON LOCK NUT AND TIGHTEN. CHECK NUT PERIODICALLY TO ENSURE IT REMAINS TIGHT AGAINST HAMMER HEAD MATING SURFACE.